

Design of Battery Energy Storage System (BESS) with Fuzzy Control for Pico Hydro

Chia Y. Kang^{1,2}, Hadi Nabipour², Hong S. Chua², and Chia C. Kang³

¹Department of Polytechnic & College Community, Ministry of Higher Education, Malaysia

²Faculty of Engineering, Computing and Science, Swinburne University of Technology, Sarawak, Malaysia

³Department of Electrical & Electronics Engineering, Xiamen University Malaysia

Email: {Ckang; hschua; Hafrouzi}@swinburne.edu.my; chiachao.kang@xmu.edu.my

Abstract—Pico hydro system, a combination of hydro turbine governor, electronic load controller, and generator are outlined as one of the recommended approaches for off-grid power supply option for rural areas communities. In a conventional installation of a hydro system, an electronic load controller with proportional–integral–derivative (PID) is the best alternative to provide power balancing between power generation and load-consuming demand. However, there is always a peak in power demand during the day, but the energy consumption is low at night. This situation caused much energy to be dumped and wasted and a lack of energy management regarding the plant's power stability. Therefore, this research aimed to design fuzzy logic control (FLC) for an energy system that could meet the critical load requirement before being simulated using MATLAB SIMULINK to evaluate the effective utilization of the excess energy. Using Mamdani's methods with 25 membership rules to implement a fuzzy logic-based control system could potentially perform efficient power flow control between scenarios such as discharging, battery backup, and load supply. The result showed that this approach is a better alternative and more efficient system stabilization and energy supply by implementing fuzzy control in surplus power generation from the pico hydro system from 2 sec to 3 sec.

Index Terms—Renewable energy, fuzzy controller, battery storage system, load demand

I. INTRODUCTION

Rural electrification refers to providing electrical power to remote areas or villages, particularly those located far from towns, which frequently experience electricity shortages, resulting in serious power quality issues and damage to the electrical equipment. These issues arise due to a mismatch between hydropower generation and end-user peak demand. It is vital to use sustainable energy via a battery energy storage system that can supply power without failure, particularly in Sarawak, Malaysia, to meet the requirement and ensure a continuous supply in villages. According to Ong [1], Malaysia is a preferred clean energy leader in the region due to its geographical landscape and advanced battery energy technologists. The generator's output in terms of

voltage and frequency will be affected by various consumer loads and water turbine speed. Consequently, many electronic load controllers were invented many years ago to stabilize and maintain the pico hydro system. This effective control decreases the risk of the voltage imbalance between generation and consumer demand. An electronic load controller uses the dump load method to consume excess power and dump it into the ballast load to maintain constant output for the system [2]. Many controller methods were implemented to govern the frequency of the voltage. Ali *et al.* [3] invented a novel technique, zero switching control, to compensate for current and voltage harmonics. Meanwhile, Mulyadi *et al.* [4] introduced an integration control technique that combines flow valve control and load control in the pico hydro system. This controller will improve output performance by reducing rise time, peak time, and settling time. Fuzzy Logic Controller (FLC) is a three-stage process similar to human-thinking logic. They are fuzzification, defuzzification, and fuzzy inference. These three stages are vital in converting classical data to fuzzy data as they provide and control the output parameters within the permissible limit. In controlling motor and consumer load, it provides an accurate output result such as partially true rather than true or false [4]. Neural Networks Proportional Integral Derivative (PID) was developed to control nonlinear processes and adjust PID parameters [5]. This method has the potential to improve the learning and control algorithm, making it much faster. By varying external load and parameter variation, improved momentum aids in increasing performance. However, most of the research studies were only discussed and developed on the controller, with no mention of the possibilities of implementation with battery charging technology, which would bring many benefits to end-users, particularly during peak load demand. Hermann [6] explained and investigated battery charging via small hydropower resources in economic values and technical feasibility. Various battery and charging procedures were discovered and analyzed during the research to bring cost-effective energy services to the rural area. An algorithm for determining the equilibrium between peak demand and the battery energy storage system was also proposed [7]. The algorithm's equation determines the amount of energy discharged

Manuscript received June 15, 2021; revised August 8, 2021; accepted August 26, 2021.

Corresponding author: Chia Y. Kang (email: ckang@swinburne.edu.my).

using the Peak Reduction Strategy (PRS). The strategy is based on the sum of power for Day-Ahead Load Profiles (DALP) and equilibrium threshold line parameters. During peak hours, the stored energy will be released and supplied back to the system. In this study, two charging battery strategies were used: reverse power flow and photovoltaic (PV) generation. However, this battery energy charging system is only found in solar PV systems. Adhikary, Roy, and Mazumdar [8] proposed a new fuzzy logic controller method for controlling turbine valves and dams via a spillway gateway. Using the tabu search algorithm and the Fuzzy Delphi Method (FDM), the centroid of gravity defuzzification in MATLAB simulation was evaluated. Alternatively, Subramaniam *et al.* [9] developed the power balancing control method to transfer power to the grid, load, and battery. Power conditioning systems act as an interface across the grid, load, and battery pack. It can either charge the battery during grid outages or deliver power to local loads as deemed necessary. A detailed comparison of the effectiveness of fuzzy controllers over conventional controllers using Gaussian, triangular, and pi input fuzzy sets was previously conducted [10]. In terms of peak time and overshoot, the fuzzy-PID controller outperforms the conventional controller. However, the result is only in simulation and has not been tested in a real site installation. Meanwhile, in a PV hybrid system, a Direct Current (DC) DC-DC converter was used as a control method for battery charging and discharging [11]. The bidirectional may control others components to apply a battery management system. However, this research focused on a simple control strategy that employs a converter and a comparison. It is unfit for use in a pico hydro system, which exhibits nonlinear behavior. Sharom, Josh, and Joseph [12] designed a fuzzy controller for battery management from PV array using voltage and current from the solar panel and boost converter. Since it only considers the input of solar power generation, this method is not suitable for standalone pico hydro implementation. Still, the load power consumption in the pico hydro system varies from time to time. Toma, Mihai, and Dobrin [13] presented the effectiveness of a fuzzy controller to manage power generation from a low-energy battery energy storage system directly to frequency variations. The fuzzy controller's input is based on frequency deviations and a State of Charge (SOC). Since this Battery Energy Storage System (BESS) is uncoordinated, it contributes to the primary frequency control level. This study does not take into account load demand. Baset, Rezk, and Hamada [14] described a fuzzy logic-based energy management system with fuel cells, supercapacitor, and battery storage systems. The proposed fuzzy controller has two inputs; the load power and SOC, while the output is based on fuel cell power. Their research demonstrated that the FLC-based management strategy not only supplies the load but also keeps the battery nearly charged to ensure fuel economy. Besides, the operation performance of the power system has been improved. However, it only uses 12 membership rules with if-then. The number of membership rules may

be increased to improve accuracy and performance in management strategy. Rehman and Riaz [15] were sensing and controlling frequency variation in an electronic load controller using a zero-crossing technique. It works by calculating and measuring the frequency range and comparing it to a predefined value. However, this wastes energy due to the addition of dummy loads. Therefore, a battery energy storage system could be employed in the future.

II. PICO HYDRO SYSTEM

The overall block concept of the pico hydro system is shown in Fig. 1. In rural areas, a pico hydro power plant with a battery energy storage system is installed to resupply power to the system during peak load demand. Since batteries supply energy in DC, a DC to alternating current (AC) controller was developed and connected to the pico hydropower plant.



Fig. 1. The whole concept of pico hydro system with battery controller.

Three primary parts of the concept, namely battery storage system, DC to AC controller, and hydropower plant are developed in MATLAB Simulink to demonstrate the efficiency of the battery energy management system.

A. Hydro Power Plant

A pico hydro power plant model was developed in MATLAB, as shown in Fig. 2. This model includes a nonlinear hydraulic model of a hydro turbine governor, a synchronous machine with 200MVA, and a 13.8kV excitation system. A servo motor and a PID controller are used in the nonlinear hydro turbine governor. The speed of the synchronous machine was fed back to the hydro turbine governor as a reference speed, allowing it to control the signal and cause a change in gate opening. In other words, the hydro turbine model will react in response to the synchronous machine's speed deviation.

Instead of a PID controller, a fuzzy-PID controller was used as a turbine governor. Compared to other controllers, the fuzzy-PID controller is chosen because it is more stable, has a lower steady-state error, and exhibits intelligence control. Fuzzy logic, using Mamdani's Fuzzy Inference methods, was added to this system to control the servo motor, allowing the parameters to vary with time [16].

B. DC to AC Controller

Since the battery energy storage system is implemented in this research, a bidirectional flow is required to ensure the system is always stable. Fig. 3 shows a DC to AC converter connection in the system. The DC to AC converter block is comprised of inverter control, an insulated gate bipolar transistor with pulse width modulation (PWM IGBT) inverter, and also a logic control filter.

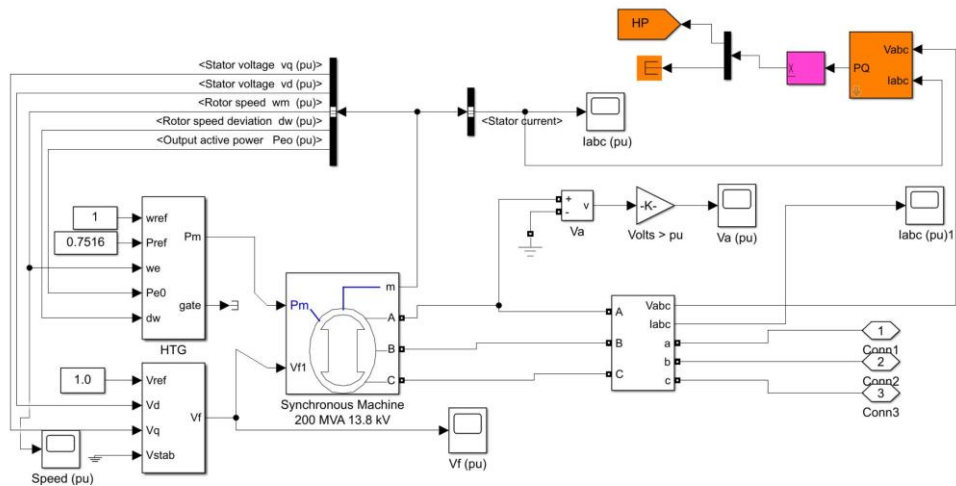

Fig. 2. Circuit modeling for pico hydro system.

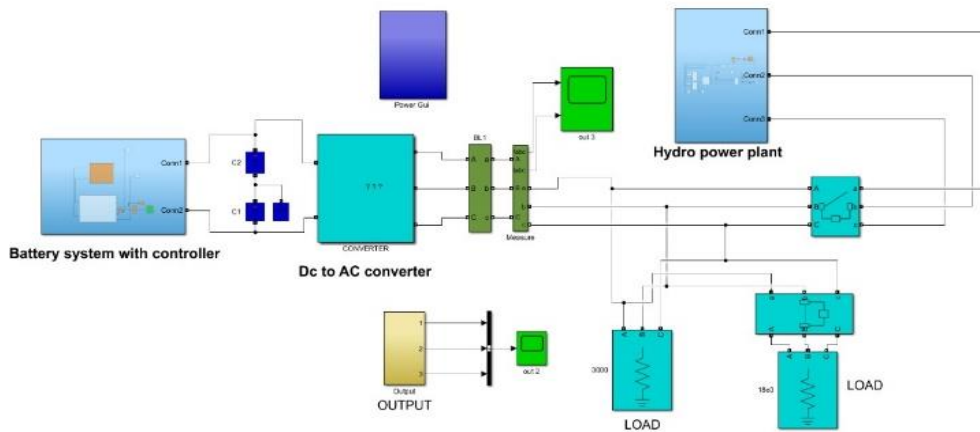

Fig. 3. DC to AC converter in MATLAB Simulink.

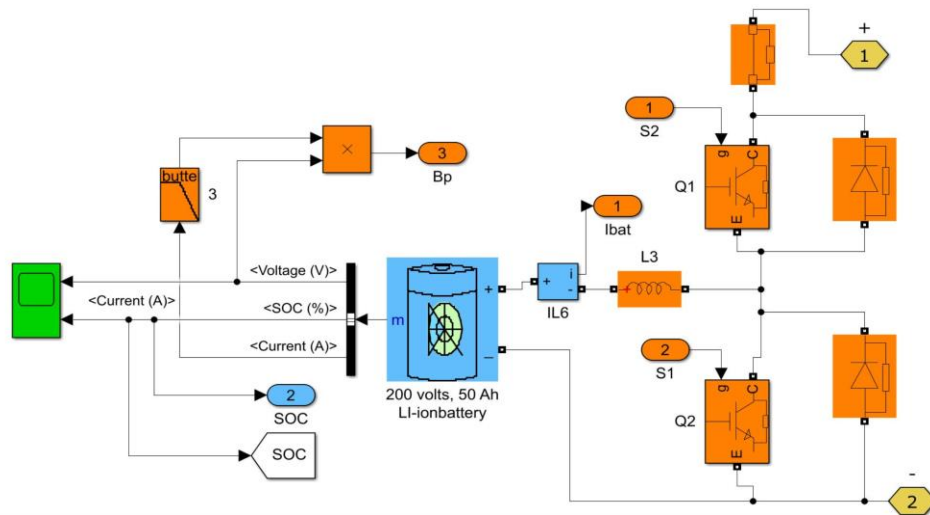

Fig. 4. BESS system with 200V, 50Ah Li-ion battery.

During peak demand, power can flow from the pico hydropower plant to the battery (charging status) or from the battery storage system to the hydropower plant (discharging) as a loaded supply. In charging mode, the battery will store the generated energy from the pico hydropower plant, whereas in discharging mode, the battery will deliver a smooth output power.

C. BESS

1) Battery implementation

In a conventional pico hydro system installation, a pico hydro plant always has to serve peak power demand issues and energy wasted during low power demand. This situation leads to a flawed system's overall factor. The

BESS is the primary component of this research, and it was designed and developed to ensure the continuous power supply in rural areas. This system was enhanced

with intelligent control, such as fuzzy logic, to improve system efficiency. Fig. 4 shows a battery system built with a 200V, 50Ah lithium-ion (Li-ion) battery.

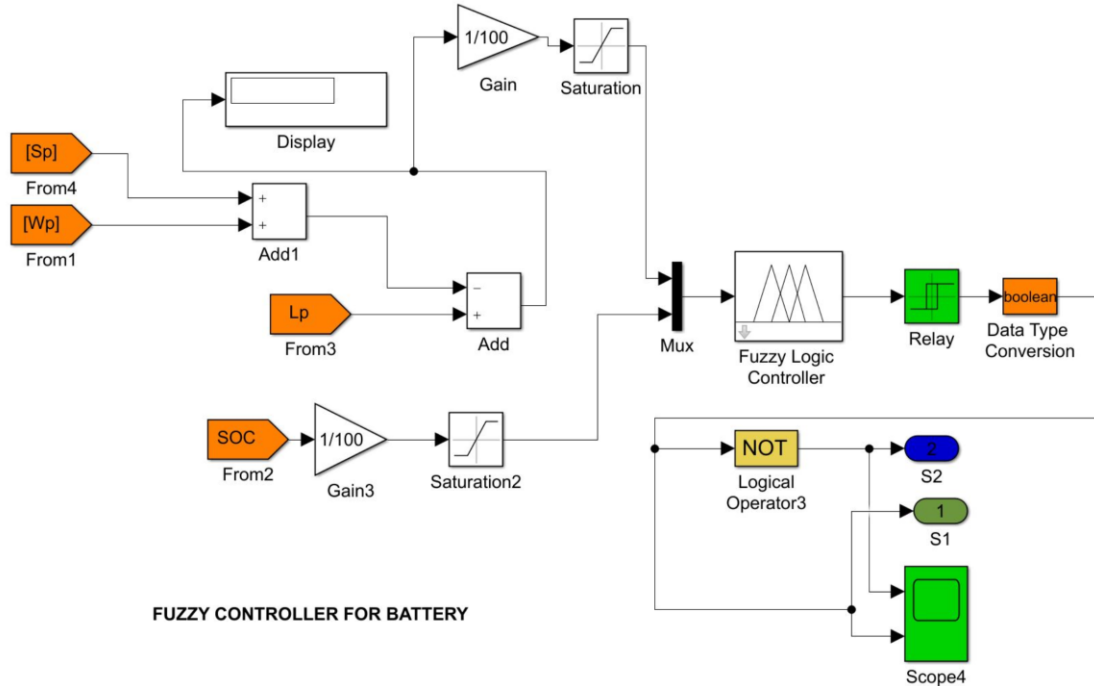

Fig. 5. BESS with fuzzy logic.

Li-ion battery was chosen for this research due to its high energy and power density in various industrial applications, particularly grid and renewable energy storage. The cell's thin, lightweight, and insubstantial characteristics make it a suitable choice over other types of batteries. The equation below could be applied to calculate the power output of the charging:

$$\text{Power charging output} = \frac{\text{Capacity battery}}{\text{Charging efficient} \times 24\text{h}}$$

Around 490W output is expected with a minimum 50Ah Li-ion battery, 200V, and 85% charging efficiency. The initial SOC was set to 95%.

2) Battery controller

An intelligent fuzzy was added to the battery controller to control the output charging and discharging mode. Fig. 5 shows the fuzzy logic model's control system, which has two inputs and one output.

In this study, fuzzy logic with Mamdani's method was developed and designed to control the charging process. The fuzzy logic design was classified into fuzzification, inference system, and defuzzification. Fuzzification is determined by the range and shape of the membership function (Table I).

TABLE I: FUZZY MEMBERSHIP SYSTEM FOR BATTERY CONTROLLER

| P/SOC | NB | NS | ZO | PS | PB |
|-------|----|----|----|----|----|
| NB | PB | PB | PB | PB | PB |
| NS | PB | PB | PS | PS | PB |
| ZO | ZO | ZO | ZO | PS | PB |
| PS | NS | NS | NS | NS | PB |
| PB | NB | NB | NB | NB | PB |

NB = Negative Big, NS = Negative Small, ZO = Zero, PB = Positive Big Medium, PS = Positive Small

The total number of rules used in the rule editor study was 25, where $P^Q = 5^2 = 25$, whereby P is total number of fuzzy sets overlapped and Q is degree of membership for state of charge. Fig. 6 displays the membership function in MATLAB Simulink. The membership function inputs were power and SOC, while the output of the membership function was battery current. For the positive and negative values of the valuables, all of the membership functions were symmetrical. It is classified as negative big (NB), negative small (NS), zero (ZO), positive small (PS), and positive big (PB) (Table I). When the battery current is negative, it indicates that the battery is discharging, whereas when the battery current is positive, it indicates that the battery is charging.

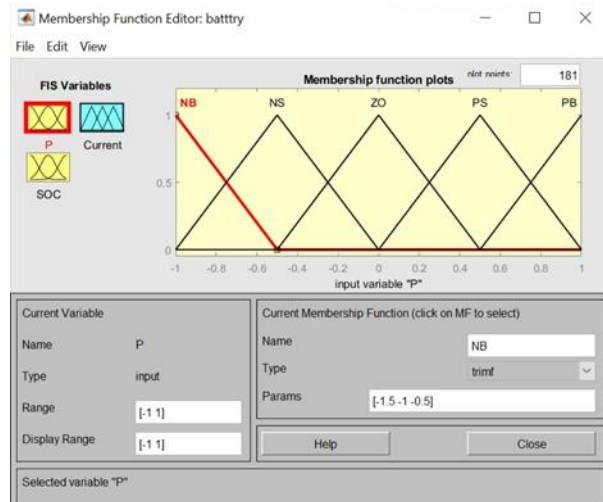

Fig. 6. Membership function for battery controller.

The output of the fuzzy logic battery controller will be monitored based on the input from the load power demand and the SOC percentage. It will be connected to the battery system via the metal oxide semiconductor field-effect transistor (MOSFET) switch, determining whether to discharge or charge the battery. In this research, a three-phase breaker was added to the extra load (200W) and turned on for 2 sec to 3 sec to demonstrate that the system is in peak load demand. The fuzzy logic battery controller will perform control action based on the immediate connection of extra load.

III. PERFORMANCE ANALYSIS

A total simulation time of battery voltage was set from 0 sec to 4 sec to demonstrate efficient battery energy management in the pico hydro system (Fig. 7). The initial SOC for LI-ion battery was 95%, which was considered nearly total capacity. Fig. 8 shows a tremendous decline from 2 sec to 3 sec. This trend indicated that the battery was on discharging mode when an extra load was connected to the circuit during the time interval.

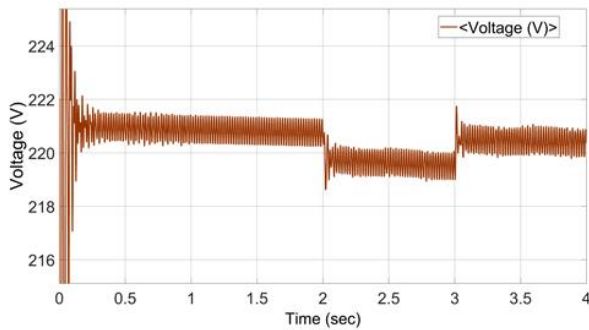

Fig. 7. Simulation analysis for battery voltage.

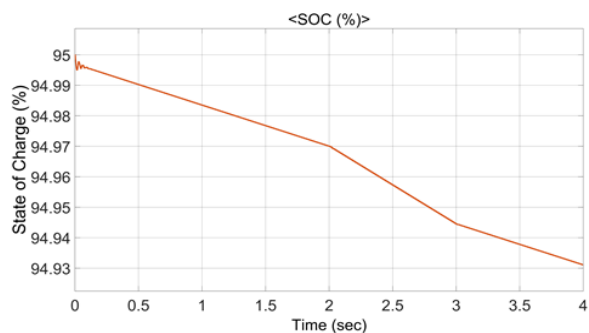

Fig. 8. Simulation analysis for the SOC (%).

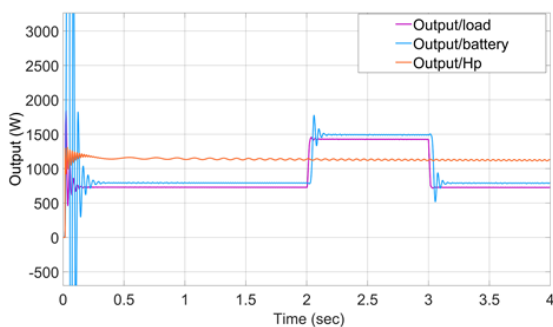

Fig. 9. Output simulation for load, battery, and hydropower.

The battery voltage dropped from 218V to 217V due to extra load between the 2nd sec and 3rd sec. The pattern indicated that charging and discharging were determined by the battery controller based on total load power and SOC. After 3 sec, the circuit breaker disconnects automatically, and the system resumes regular operation under typical load demand situations. Fig. 9 shows the output comparison of the load and the battery.

The above waveforms represent the power waveforms of the energy storage system, which consists of a battery and a load. It is observed that the yellow line (output for load) is compensated by battery power at the start of the simulation, indicated the battery is in charging mode. When the load increased from 2 sec to 3 sec during simulation, the battery is discharged and injected power into the system. The battery returns to charging mode after the 3-second load decreases. When there is a surplus of power generated by the pico hydro turbine, this process makes the energy management system more efficient and adaptable.

IV. CONCLUSION

The primary objective of this investigation was to keep the pico hydro system performing well and supplying energy even during peak load demand hours, particularly in rural areas. Adding battery energy storage to a pico hydro system is also one of the best ways to ensure a consistent and sufficient power supply. The required numbers for designing a pico hydro battery energy storage system are determined by technical, battery type, and other environmental parameters. The controller is an essential part of this research since it ensures that the system is functioning correctly. Fuzzy logic, with its intelligence feature, has been implemented in battery energy storage systems. Mamdani's method has been proposed, and the model is fundamental. Although previous research on battery charging and discharging processes has been conducted, battery control technology for industrial use has not yet been established. Furthermore, some of the batteries are expensive and not environmentally friendly. This work can be expanded by incorporating various fuzzy-logic-linguistic variables to predict more accurate and efficient control based on membership rules.

CONFLICT OF INTEREST

The authors declare no conflict of interest.

AUTHOR CONTRIBUTIONS

Hadi Nabipour, Hong Siang Chua, and Chia Chao Kang are the corresponding authors. They also supervised the written paper and provided the necessary complement analysis in this research.

ACKNOWLEDGMENT

The Swinburne University of Technology, Sarawak, had supported this work.

REFERENCES

- [1] S. Ong. (2019). Malaysia can be major energy storage supplier. *The Malaysia Reserve*. [Online]. Available: <https://themalaysianreserve.com/2019/12/27/malaysia-can-be-major-energy-storage-supplier/>
- [2] P. Sritha and G. Preethi, "ARM based electronic load controller for micro-hydropower stations," in *Proc. IOP Conf. Series: Mater. Sci. Eng.*, vol. 764, 2020.
- [3] A. Ali, H. Akhtar, M. U. R. Siddiqi, and M. Kamran, "An efficient and novel technique for electronic load controller to compensate the current and voltage harmonics," *Eng. Sci. & Technol.*, vol. 23, no. 5, pp. 1042-1057, Oct. 2020.
- [4] R. Mulyadi, M. Effendy, I. Pakaya, and Zulfatman, "Analysis of integration flow control valve and electronic load controller for micro hydro power plant frequency regulation," in *Proc. IOP Conf. Series: Mater. Sci. Eng.*, vol. 403, 2018.
- [5] A. Zribi, M. Chtourou, and M. Djemel, "A new PID neural network controller design for Nonlinear process," *J. Circuit. Syst. Comput.*, vol. 27, no. 4, 2018.
- [6] S. Hermann, "Design of a micro hydro powered battery charging system for rural village electrification," Master dissertation, Department of Physics, Faculty of Mathematics and Science, Carl Von Ossietzky University of Oldenburg, Germany, 2006.
- [7] M. Shamshiri, C. K. Gan, J. Sardi, M. T. Au, and W. H. Tee, "Design of battery storage system for Malaysia low voltage distribution network with the presence of residential solar photovoltaic system," *Energies*, vol. 13, no. 18, 2020.
- [8] P. Adhikary, P. K. Roy, and A. Mazumdar, "Safe and efficient control of hydro power plant by fuzzy logic," *Int. J. Eng. Sci. Adv. Technol.*, vol. 2, no. 5, pp. 1270-1277, 2012.
- [9] U. Subramaniam, S. Vavilapalli, S. Padmanaban, F. Blaabjerg, J. B. Holm-Nielsen, and D. Almkhles, "A hybrid PV battery system for ON – Grid and OFF grid applications – controller in loop simulation validation," *Energies*, vol. 13, no. 3, 2020.
- [10] K. A. G. Rao, B. A. Reddy, and P. D. Bhavani, "Fuzzy PI and integrating type fuzzy PID controllers of linear, nonlinear and time delay system," *Int. J. Comput. Appl.*, vol. 1, no. 6, pp. 41-47, 2010.
- [11] H. Ibrahim and M. Ghandor, "Optimization of energy management of a microgrid based on solar-diesel-battery hybrid system," presented in MATEC Web Conf., Jan. 2018.
- [12] I. L. B. Shalom, F. T. Josh, and M. J. J. Joseph, "Battery modelling for a photovoltaic system with battery management system using fuzzy logic controller," *Int. J. Recent Technol. Eng.*, vol. 8, no. 1S2, pp. 335-339, May 2019.
- [13] L. Toma, S. Mihai, and B. P. Dobrin, "Fuzzy logic based battery energy storage system control for frequency containment," in *Proc. 12th International Symposium on Advanced Topics in Electrical Engineering*, 2021, pp. 1-6.
- [14] D. A. Baset, H. Rezk, and M. Hamada, "Fuzzy logic control based energy management strategy for renewable energy system," in *Proc. Int. Youth Conf. on Radio Electronics, Electrical and Power Engineering*, 2020, pp. 1-5.
- [15] U. U. Rehman and M. Riaz, "Design and implementation of electronic load controller for small hydro power plants," presented at 2018 International Conference on Computing, Mathematics and Engineering Technologies, 2018.
- [16] C. Y. Kang, H. Nabipour, H. S. Chua, and C. C. Kang, "Analysis of integration controller for pico hydro power plant using fuzzy-PID control technique," [unpublished], 2021.



Kang Chia Yang is a lecturer at the Polytechnics of Kuching, Sarawak. He earned a bachelor's degree in Electrical System Engineering from the University Malaysia Perlis. Kang Chia Yang is also a Master of Engineering student at the Swinburne University of Technology Sarawak. His research focuses primarily on the performance of load controllers in pico hydropower systems. He is also a member of the Institute of Engineering & Technology (IET), the Institute of Engineering Malaysia (IEM), and the Malaysia Board of Technology (MBOT). He also contributes to several international journals on topics such as power quality and harmonic distortion. Besides that, he is also a certified professional trainer by HRDF & CIDB Malaysia and is involved in construction training.



Hadi Nabipour Afrouzi graduated with honours from the Department of Electrical Engineering and Electronics at Azad University of Bojnourd, Iran, in 2005. In 2011, he received his Master of Electrical Engineering from Universiti Teknologi Malaysia (UTM). In 2015, he earned his Doctorate from the same university (UTM). Dr. Hadi began working as a lecturer in the Faculty of Engineering, Computing, and Science at Swinburne University of Technology (Sarawak Campus). His research interests include partial discharge, insulation condition monitoring, fault modelling and simulation in high voltage insulators, and renewable energy.



Chua Hong Siang earned a B.Eng. (Hons) degree in Communication and Control Engineering from UMIST, U.K., in 2002. After completing his first degree, he joined the Microwave Engineering group in the Department of Electrical and Electronic Engineering as a Ph.D. research student under the joint sponsorship of Overseas Research Studentship (ORS), U.K., and Engineering and Physical Sciences Research Council (EPSRC), the U.K. He received the IEE Robinson Research Scholarship in 2003 and 2004 while conducting his research. In addition, he received an IEE travel grant in June 2005 to present a paper at the IEEE MTT-s Conference in Long Beach, California. In January 2006, he completed his Ph.D. by submitting his thesis titled "Characterisation of wheat grain using a microwave, terahertz, and magnetic resonance imaging techniques." His primary research interests include applying microwave sensors for food characterisation, optical sensors for chemical characterisation, and micro-grid modelling and simulation.



Kang Chia Chao is currently a senior lecturer at Xiamen University Malaysia. He is a registered Graduate Engineer under the Board of Engineering Malaysia (BEM), a member of the Malaysian Society of Engineering Technology (MySET), a member of the Malaysia Board of Technologists, and a member of the Institute of Electrical and Electronic Engineering and Technology (IEEE). Kang Chia Chao earned a Bachelor of Electrical & Electronic Engineering from Northumbria University in Newcastle upon Tyne, a Master of Science in Electronic System Design Engineering, and a Doctor of Philosophy in Microwave and System Satellite from the University of Science Malaysia. He previously worked as a product engineer for several years in the electrical and electronic fields before joining as an academician. Besides that, he is also a professional trainer certified by HRDF Malaysia, a member of the First Aid and Emergency Response Team, and a certified thermography level (1).

Copyright © 2022 by the authors. This is an open-access article distributed under the Creative Commons Attribution License ([CC BY-NC-ND 4.0](https://creativecommons.org/licenses/by-nc-nd/4.0/)), which permits use, distribution and reproduction in any medium, provided that the article is properly cited, the use is non-commercial and no modifications or adaptations are made.