

**Research Paper****HIGH EFFICIENCY THREE PHASE TRANSFORMER LESS MOSFET INVERTER TO DRIVE PMSM MOTOR**A Uma Siva Naga Prasad<sup>1\*</sup>*\*Corresponding Author: A. Uma Siva Naga Prasad, ✉ ausn43@gmail.com*

A project proposed a new high efficiency Three phase transformer-less photovoltaic (PV) inverter by using super-junction MOSFETs as main power switches. Here fifteen level topologies have been implemented by using H-Bridges. Fundamental switching scheme and Selective Harmonics Elimination were implemented to reduce the Total Harmonics Distortion (THD) value. The proposed inverter can also operate with high frequency by retaining high efficiency which enables reduced cooling system. To reduce the power demands scarcities, to minimize the electromagnetic interferences and to increase the energy efficiency by reducing the number of switches and size of output filter. Multilevel inverters are used to extract the power from solar cells. It also synthesizes the desired AC output waveforms from several dc sources. The simulation result shows the proposed system reduces the power demand scarcity and increase the efficiency using MATLAB/Simulink.

**Keywords:** Three phase transformer, MOSFET, Multi level inverters, Total Harmonic Distortion, PMSM motor, PV array

**INTRODUCTION**

Nowadays a high quality power is needed for medical research and industrial applications, to bring being good quality results for accurate evaluation. Multilevel inverters continues to receives more and more attentions because of the high voltage operation capabilities, low switching loss high efficiency and low outputs of electromagnetic interferences (EMI). The preferred output of a multilevel inverter is synthesis by several sources of dc voltages. An attempts has been made upto improves the

quality of powers. With an increasing the number of dc voltage sources, the inverter voltage waveforms approach a nearly sinusoidal waveforms while a using low switching frequency scheme. This result causes a low switching loss, and because several dc sources are used to synthesis the total output voltage, each experiences a lower dv/dt compared to a single level inverter. Consequently, the multilevel inverter technology is a promising technology for high power electric devices such as utility applications (Mechouma R *et al.*, 2012).

<sup>1</sup> Assistant Professor, Wolaita Sodo University, Ethiopia.

The ac output voltage has obtained from inverters can be fed to a load directly or interconnects to the ac grid without voltage balancing problem. The multilevel inverters offer several advantages as compared to hard-switched two level pulse width modulation inverters, such as capabilities to operates at high voltage with lower dv/dt per switching high efficiency, low electromagnetic interference system (Kerekes *et al.*, 2007).

The Asymmetrical configuration of Eleven level inverter based (ELI) multi String multi level topology methods fed to three phase induction motors drive performance is analyzed been compared with a conventional cascaded H-bridge multilevel inverter and the performance factors are obtained at both transient and steady state operating conditions with usage of minimum number of switches so that switching losses can be reduced effectively with multi string multilevel approach. Performance Analysis of Eleven Level Asymmetrical Multi String Multi Level Inverter fed Three Phase Induction Motor Drives (Mekhilef S, 2010; and Barater D *et al.*, 2009).

The cascade multilevel inverter was first proposed in 1975 (Amjad M *et al.*, 2013). In recent years multi level inverters has used high power voltage applications. Multilevel inverter output voltage produces has staircase outputs waveform, this waveforms look like sinusoidal waveform. The multilevel inverter output voltage having a less number of harmonics compare to a conventional bipolar inverters output voltage. If multilevel inverters output increases

to n level, the harmonics reduced to be output voltage values equal to zero (Araujo S V *et al.*, 2010 and Bremicker S *et al.*, 2010). High efficiency over a wide range of load is achieved by using MOSFET's as main switches. The multilevel inverter has produces a common mode voltage, to reduced the stress of the motor.

## CASCADE MULTILEVEL INVERTER

Cascaded multilevel inverters made up of series connected single full bridge inverters, each with their own isolated dc bus. This multilevel inverter can generates almost sinusoidal waveforms voltage from several separates dc sources, which may be obtained from solar cells, fuel cells, battery, ultra capacitors, etc. This type of converters does not need any transformers or clamping diodes or flying capacitor. Each level can be generates five different voltage outputs +2Vdc, +vdc, 0, -2Vdc and negative vdc by connecting their dc source to their ac outputs side by different combinations of their four switches. The output voltages of an M-level inverter are the sum of all individual inverter outputs. Each of their H-Bridges active devices switches only at the fundamental frequencies, and each H-bridge units generates a quasi- square waveforms by phase shifting its positive and negative phase legs switching timings. Further, each switching devices always conducts from 180° (or half cycle) regardless of these pulse width of the quasi square wave, so that this switching methods results to equalize this current stress of each active device. The general block diagram of cascade multilevel inverter is shown in Figure 1.

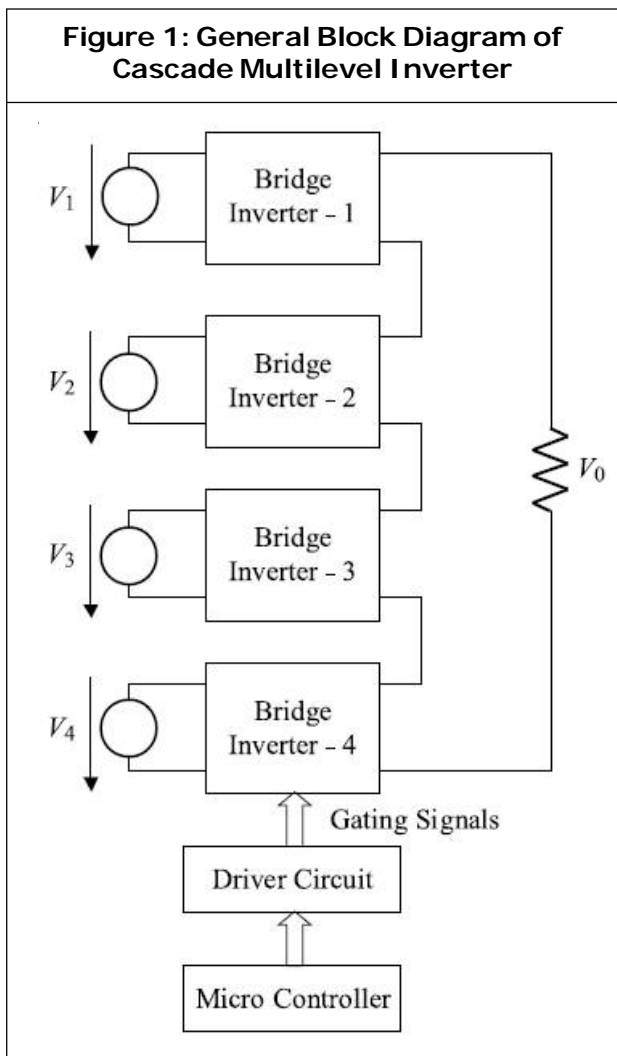

These topology level inverters are suitable for high voltage and high power inversions because of its ability of synthesize waveforms with better harmonics spread spectrum and low switching frequencies. Considering their simplicity of the circuits and advantages, Cascaded H-bridge topology is chosen for their presented works. A multilevel inverter has been four main advantages over the conventional bipolar inverters. First, the voltage stress for each switch is decreased, due to series connections of the switches. Therefore, the rated voltage and consequently the total power of the inverters could be

safely increased. Second, the rate of change of voltage ( $dv/dt$ ) is decreased due to the lower voltage swing of each switching cycles. Third, harmonic distortions are reduced due to the more output levels. Fourth, lower acoustic noise and electromagnetic level interference method (EMI) is obtained.

### FIFTEEN LEVEL MULTILEVEL INVERTER TOPOLOGY

Lastly, seven switching angles were calculated for 15-level CMLI for its 7 H-bridges using N-R method. In this case, more number of harmonic components (six) as compared to 7 and 11 level CMLIs THD contents in output voltage reduces appreciably. The harmonic components eliminated are 5th, 7th, 11th, 13th, 17th and 19th. It is to be noted here that among different solution sets of switching angles computed as above, the THD is computed by using those switching angles which are producing minimum THD (this applies for the values of  $m$  where multiple solution exist).

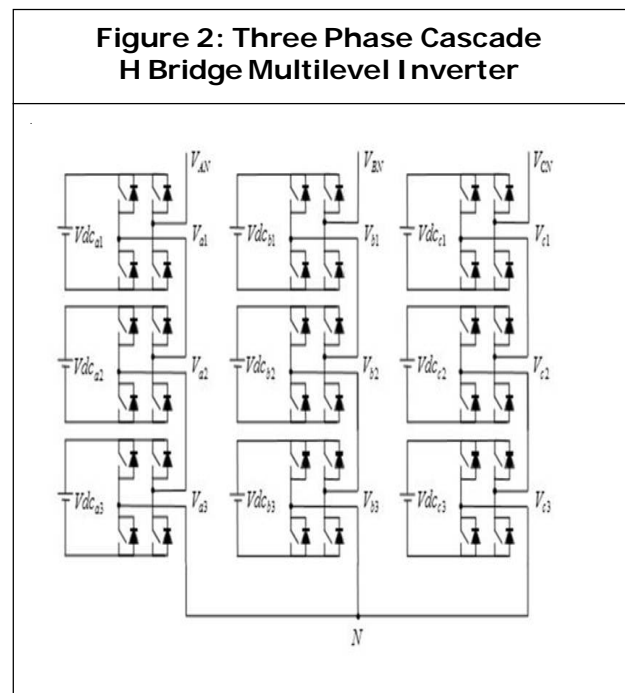

The THD level in output voltage is strictly satisfying IEEE-519 standard for normal working range of modulation indices. Some of calculated switching angles have been shown in Table III for reference. By bringing THD level below threshold value is very significant as THD produces various losses and undesirable effects in electric power systems and equipments. The Figure 3 shows three phase fifteen level inverter circuit diagram.

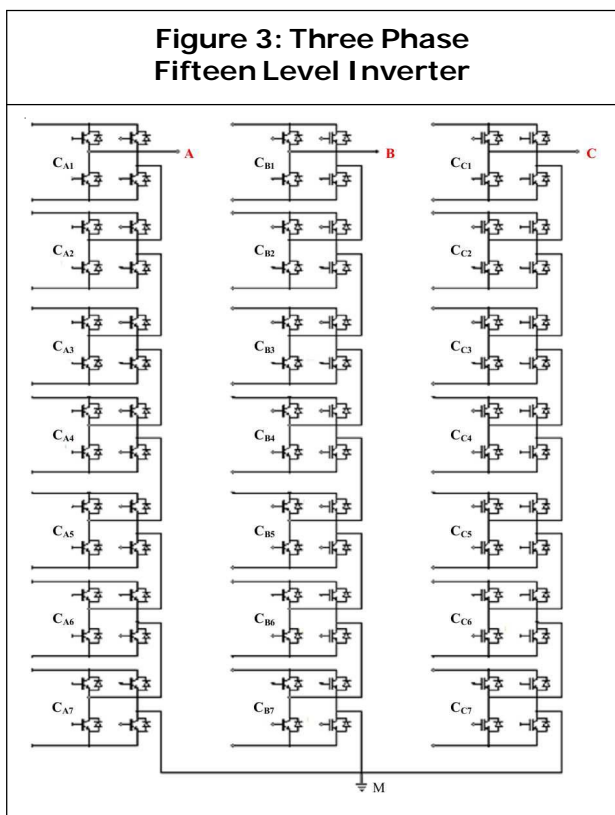

The range of modulation index for which solution for switching angles exist decreases with the increase in number of levels but the occurrence of multiple solutions increase with the increase in number of level i.e. for 7-level inverter only two sets of solution exist, for 11-level four sets of solution exist and for 15-level nine sets of solution are obtained thereby making computation more complex with

number of levels. It can be observed from this figure that the THD reduces with the increase in number of levels.

**Table**

$m$	$\alpha_1$	$\alpha_2$	$\alpha_3$	$\alpha_4$	$\alpha_5$	$\alpha_6$	$\alpha_7$
0.42	0.601	0.757	0.920	1.093	1.292	1.540	1.554
0.47	0.590	0.733	0.873	1.028	1.190	1.386	1.565
0.60	0.249	0.585	0.681	0.914	1.027	1.164	1.474
0.70	0.108	0.374	0.558	0.747	0.866	1.073	1.300
0.75	0.119	0.319	0.427	0.621	0.867	0.994	1.185
0.80	0.126	0.228	0.364	0.484	0.683	0.952	1.095

The main three MLI configurations are neutral point converter, flying capacitor and cascaded H-bridge multilevel inverter. CHMI has more advantages than other two mentioned. Some phases of switching angles are mentioned in radians.

### SELECTIVE HARMONIC DISTORTION

An important key in designing an effective and efficient cascaded H-bridge multilevel inverter is to ensure that the total harmonic distortion (THD) in the output voltage waveform is small enough. It is worth noting that in most of the works reported in the technical literature, the level of the dc sources was assumed to be equal and constant, which is probably not to be case in application even if the sources are nominally equal. The Selective Harmonic Elimination (SHE) has been intensively studied in order to achieve low THD.

This technique is used to solve the harmonic elimination equations based on stepped waveform analysis in order to obtain the optimal switching angles which in turn reduce the Total Harmonic Distortion (THD). Harmonics is an important concern in all utility

sectors. However, the electric utilities are recently designed to monitor and analyze the existence and effects of distortion on system and customer devices. The factors contribute the harmonic distortion on distribution systems are increased application of capacitors and non linear devices. In order to improve the power quality and to maintain stable power supply performance, an inverter control strategy with harmonic reduction techniques can be employed. Spectral analyses of the simple voltage and the compound voltage, performed by Matlab /Simulink. According to the simulation results, fundamental of simple voltage is 309V and fundamental of compound voltage is 535.1V. The rate harmonic is then 10.35% for simple voltage and 9.75% for compound voltage.

**SIMULATION RESULTS**

MATLAB 13 version with Simulink is used for simulation purposes under windows 8 platform. A single-phase photovoltaic power supply unit is designed. The distribution system in INDIA is three phase four wire 415 Volts, 50Hz ac supply. Bulk of the domestic loads operates

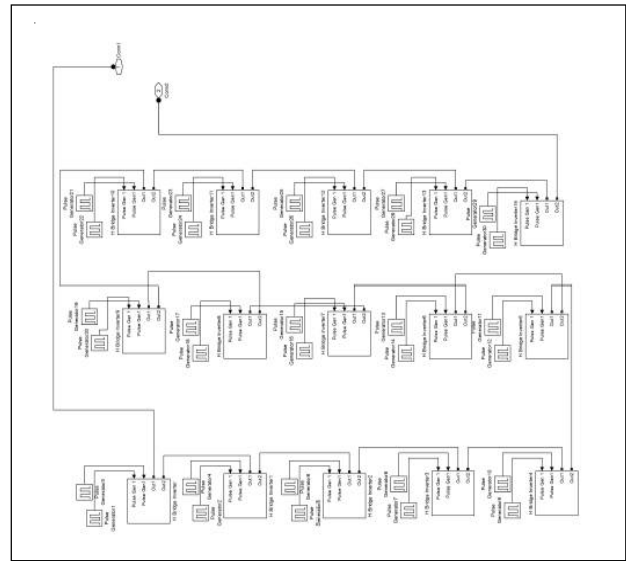

from single phase 230V, 50 Hz ac system. The Figure 4 shows the simulation circuit diagram of the proposed system.

So the output voltage of the proposed power supply is designed for 230 Volts ac supply for the grid. The peak output voltage of the inverter is 400 volts. For a fifteen-level inverter, seven half-Bridge cells are connected in cascade. The dc bus voltage of individual half bridge cells is 54volts. The Figure 5 shows the simulation results.

**Figure 4: Simulation Circuit Diagram**

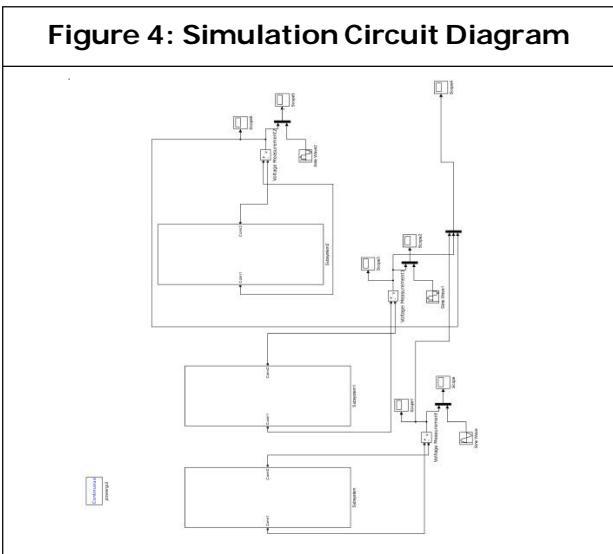

**Figure 5: Simulation Graph**

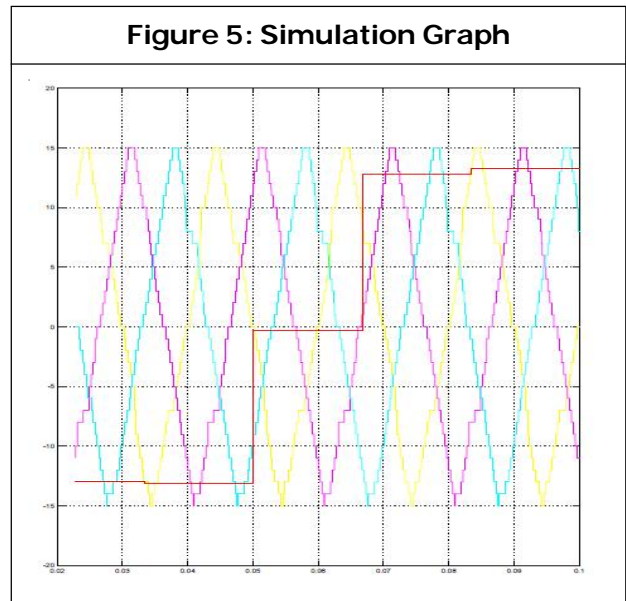

## CONCLUSION

Multilevel inverters are very suitable for PV generation. H-bridge cell with PWM control is very promising solution. Not only for having medium and high voltages but also improving the quality of voltage by reducing the harmonics. The inverter is powered by various PV sources. It gives the amplitude of the fundamental and the value of harmonic distortion output voltages. The inverter has two major tasks: to inject a sinusoidal current into the grid and to optimize the operating point of the PV modules, to capture the maximum amount of energy.

## REFERENCES

1. Amjad M, Salam Z, Facta M and Mekhilef S (2013), "Analysis and Implementation of Transformerless LCL Resonant Power Supply for Ozone Generation", *IEEE Transactions on Power Electronics*, Vol. 28, pp. 650-660.
2. Araujo S V, Zacharias P and Mallwitz R (2010), "Highly Efficient Single-Phase Transformerless Inverters for Grid-Connected Photovoltaic Systems," *IEEE Transactions on Industrial Electronics*, Vol. 57, pp. 3118-3128.
3. Barater D, Buticchi G, Crinto A S, Franceschini G and Lorenzani E (2009), "A new proposal for ground leakage current reduction in transformerless grid-connected converters for photovoltaic plants", in *35th Annual Conference of IEEE Industrial Electronics (IECON '09)*, pp. 4531-4536.
4. Bremicker S, Greizer F and Victor M (2010), "Inverter, more specifically for photovoltaic plants", Ed: Google Patents.
5. Huafeng X, Shaojun X, Yang C and Ruhai H (2011), "An Optimized Transformerless Photovoltaic Grid-Connected Inverter", *IEEE Transactions on Industrial Electronics*, Vol. 58, pp. 1887-1895.
6. Kerekes T, Teodorescu R and Borup U (2007), "Transformerless photovoltaic inverters connected to the grid", in *Twenty Second Annual IEEE Applied Power Electronics Conference (APEC)*, pp. 1733-1737.
7. Kerekes T, Teodorescu R, Rodri X, Guez P Va, et al. (2011), "A New High-Efficiency Single-Phase Transformerless PV Inverter Topology", *IEEE Transactions on Industrial Electronics*, Vol. 58, pp. 184-191.
8. Mechouma R, Azoui B and Chaabane M (2012), "Three-phase grid connected inverter for photovoltaic systems, a review", in *First International Conference on Renewable Energies and Vehicular Technology (REVET)*, pp. 37-42.
9. Mekhilef S (2010), "Dual vector control strategy for a three-stage hybrid cascaded multilevel inverter", *Journal of Power Electronics*, Vol. 10, pp. 155-164.
10. Victor M, Greizer, Bremicker S and Hübler U (2008), "Method of converting a direct current voltage from a source of direct current voltage, more specifically from a photovoltaic source of direct current voltage, into a alternating current voltage," ed: United States Patents.